

HAPPY R-TYPE

LIFTING HEAVY
CARGO FOR
WORLDWIDE
TRANSPORT



BIGLIFT

SAFE
SAILINGS

HAPPY R-TYPE



HAPPY R-TYPE

HAPPY RIVER, HAPPY ROVER, HAPPY RANGER

HATCH OPENINGS AND ALLOWABLE LOADS

HATCH OPENINGS	
weather deck	91.0 x 17.7 m
tween deck	87.5 x 17.6 m

ALLOWABLE LOADS	
weather deck hatch covers	12.5 t/m ²
tween deck hatch covers	10.5 t/m ²
tank top	20.0 t/m ²

FLOOR SPACE	
weather deck	2,450 m ²
tween deck	1,525 m ²
tank top	1,386 m ²

CRANES

2 x 400 mt SWL

COMBINABLE
800 mt

TROLLEY
25 mt SWL

PRINCIPAL DIMENSIONS

Length overall	138.00 m
Length p.p.	127.90 m
Breadth moulded	22.88 m
Breadth extreme	23.19 m
Summer draft	9.50 m

REGISTRATION

The Netherlands

CLASS

Lloyd's X100 A1 XLMC-UMS
LA LNC AA strengthened for heavy cargoes Ice class
Finnish/Swedish 1A, Great lakes fitted

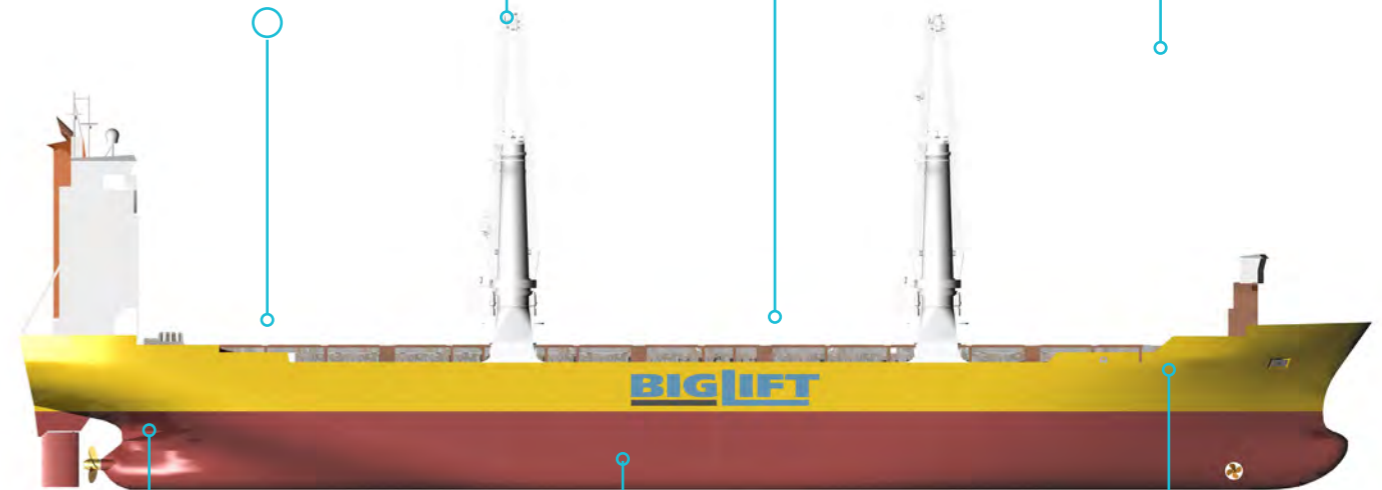

MAIN ENGINE

Wärtsilä	8775 kW
Bowthruster	850 kW
Service speed	16.4 kn at draft 7.00 m

CAPACITY

Grain = bale	17,863 m ³
If tween deck installed	16,338 m ³

DEADWEIGHT

At Summer (sea water) draft	15,634 mton inc. tween deck hatch covers, pillars
-----------------------------	---

The Happy R-types have a proven record of carrying the heaviest loads safely around the world. The vessels excel in deck strength and hatch configuration. The deck strength of the weather deck can be increased to 15 mt/m², making the vessel very suitable for special heavy cargoes such as reels and carousels. The hatch cover configuration supports fast cargo operations.

The Happy R have one single hold, enabling

to load pieces up to a length of 88 meters below deck. The tween deck pontoons can be fitted into almost any position offering endless hold configuration. The Happy R-type is equipped with two 400 mt Huisman cranes, combinable to 800 mt SWL lifting capacity.

The highest Finnish ice class gives this class the possibility to sail both northern routes and to operate in the harshest of

conditions. The vessels are also Great Lakes fitted, widening the opportunities even further.

The experienced operational staff together with the vessels' outfit ensures safe and fast operations with the highest service to all parties involved.

HAPPY R-TYPE

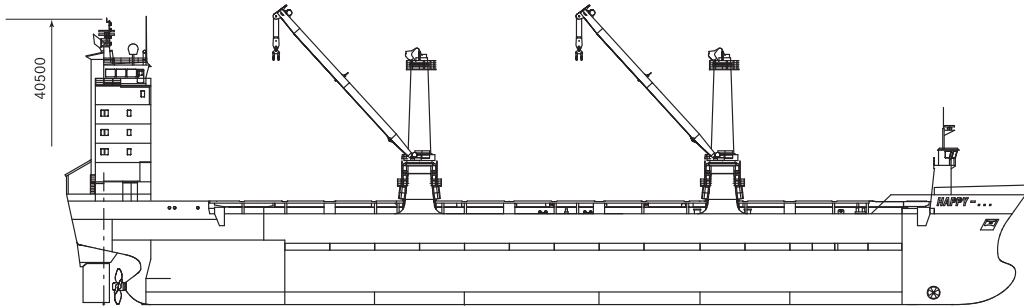

Side View

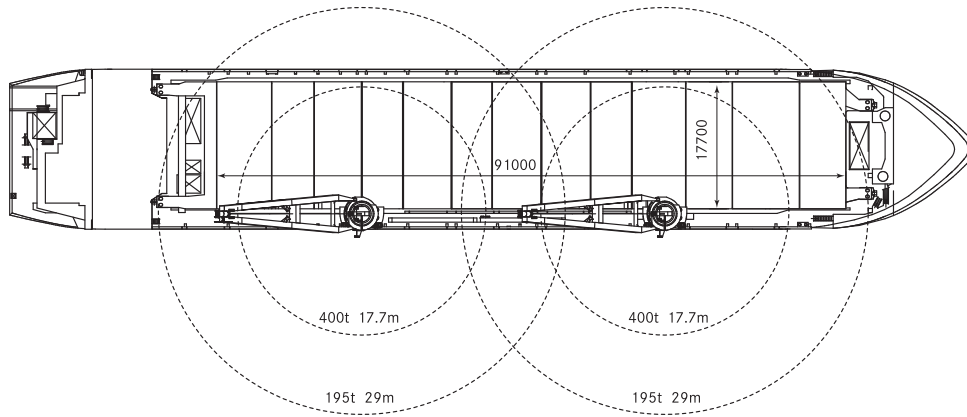

Weatherdeck

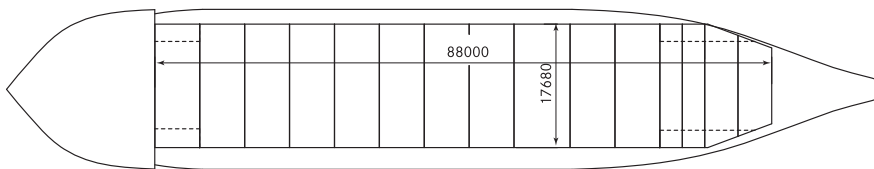

Tweendeck

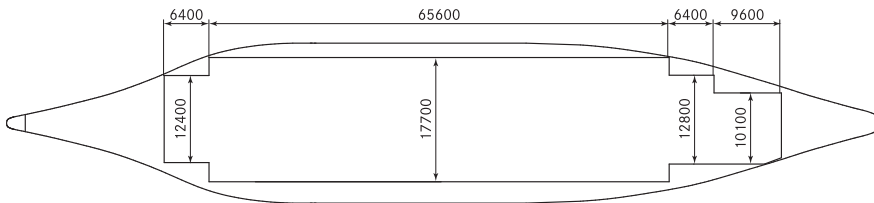

Tanktop

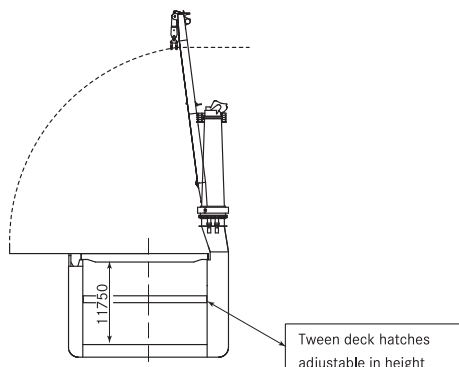

Cross section

HAPPY R-TYPE

Class	LRS ✕100 A1, LMC-UMS, LA LNC AA, Ice class 1A (Finnish/Swedish), Great Lakes fitted Strengthened for heavy cargoes		
Principal Dimensions	Length overall	138.00	m
	Length p.p.	127.90	m
	Breadth moulded	22.88	m
	Breadth extreme	23.19	m
	Summer draft	9.50	m
Deadweight	Summer (sea water)	15,634	mton
Tonnage		International	Panama
	GT	10,990	-
	NT	5,041	9,255
Capacity	Grain = bale	17,863	m ³ if tween deck installed, 16,338 m ³
Floor space	Weather deck	2,450	m ²
	Tween deck	1,525	m ²
	Tank top	1,386	m ²
Hatch openings	Weather deck	91.0 x 17.7	m
	Tween deck	87.5 x 17.6	m
Heights	Heights adjustable in 13 steps of 50 cm		
	Minimum lower hold	3.42	m maximum 8.92 m
Allowable loads	Weather deck hatch covers with pillars	4.0	t/m ²
	Tween deck hatch cover with pillars	12.5	t/m ²
	Tank top	3.5	t/m ²
		10.5	t/m ²
		20.0	t/m ²
Cranes	Combinable	800	mt SWL
	Situated on starboard side	2 x 400	mt SWL
	Fitted with trolley	25.0	mt SWL
Main engine	Wärtsilä 9L46B	8,775	kW
	Bowthruster	850	kW
	Service speed	16.4	kN at draft 7.00 m
Container capacity	1,039 TEU		

HAPPY R-TYPE

Happy Ranger	Amsterdam	The Netherlands	1998
Happy River	Amsterdam	The Netherlands	1997
Happy rover	Amsterdam	The Netherlands	1997

These particulars are believed to be correct, but without guarantee, and they must not be used as basis for Charter Parties or contracts without Owners' explicit written authority.



Radarweg 36	:	P.O. Box 2599	:	t. +31 (0) 20 - 448 83 00	:	info@bigliftshipping.com
1042 AA Amsterdam	:	1000 CN Amsterdam	:	f. +31 (0) 20 - 448 83 33	:	www.bigliftshipping.com



Radarweg 36
1042 AA Amsterdam

P.O. Box 2599
1000 CN Amsterdam

t. +31 (0) 20 - 448 83 00
f. +31 (0) 20 - 448 83 33

info@bigliftshipping.com
www.bigliftshipping.com